



GTD Series

TOP SHEET DISPENSER

CYKLOP[®]
GLOBAL PACKAGING SOLUTIONS

STRAPPING
WRAPPING
CODING
TAPING

The Goliat Top Sheet Dispenser is a very versatile and robust packaging machine for applying top cover on lumber packages and is available for four roll widths; 1300 mm, 2500 mm (standard), 3400 mm and 3700 mm. Top cover with or without antislip surface treatment is normally applied on the top and the sides of a package to protect it from rain, snow and dirt. It is also normally printed with the producer's design, for excellent advertisement.

The machine is equipped with two roll holders, one primary holder being active and one secondary holder as redundancy for quick changeover. The top cover is rolled out on top of the package while it is being transported through the machine and is automatically cut to length once the package has passed. The cover feed speed is adjustable up to nearly 40 meters per minute. The machine comes with legs for floor mounting as standard, but ceiling as well as rooftop mounts are also available as options.

Advantages

The Goliat Top Sheet Dispenser feeds top cover on various sizes of packages as well as broom packages. Its very robust and simple design warrants an efficient handling and a low maintenance cost. A twin version with double feeders is available for applications where automatic switchover between different cover widths is desired.

Options

Safety package for using the machine without area protection, custom height, end hood sealing, antistatic modules, length groups, remote controlled cutting, freely selectable length by control panel input.

Technical specifications		GTD 2500
Machine	Speed	9,6 – 38,5 m/min
	Winding	Unfolded/2-folded
Connections	Electrical supply	230V, 50 Hz, 1PH+N+PE
	Load	1,0 kW
	Pneumatic supply	6 bar, approx 12 NL/cycle
Top film	Film width	max 2500 mm*
	Diameter	max 500 mm
	Roll weight	max 200 kg
	Material	PE-film
	Thickness	80-120 µm
*) Width options available: max 1300 mm, max 3400 mm & max 3700 mm		

Dim	Height	Width	Depth	Weight
Standard	2825 mm	3440 mm	1200 mm	≈650 kg

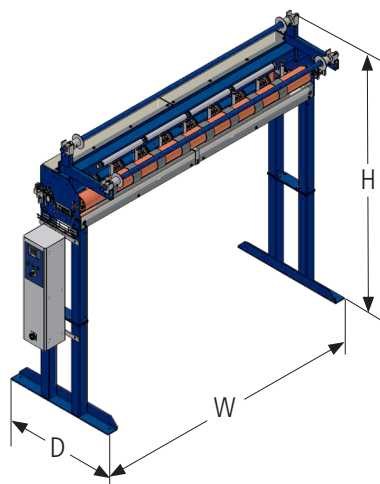

Rooftop twin version (Double set of roller holders)



Ceiling mounted version



GTD 2500